



maia xc

User Manual



aethra®
keep connected

Welcome

Thank you for choosing a AETHRA® SpA. Product.

Inside you will find useful information to help you get the most out of the Aethra product.

The information contained in this document is the property of Aethra SpA., it is subject to change without notice and it shall in no way be binding for Aethra SpA

© Copyright Aethra Telecomunicazioni SpA 2007.

MS, Microsoft and NetMeeting are registered trade marks of Microsoft Corporation. Windows is a trade mark of Microsoft Corporation.

All rights reserved.

Cod. 074201008GB Rev. 1 – April 2008.















Index

INDEX	3
SAFETY RULES	6
PSTN WARNING	6
ENVIRONMENTAL SAFETY	6
STATE OF CALIFORNIA PROP 65 WARNING	6
WARNINGS	6
CLEANING	6
SAFETY RULES FOR BATTERIES	7
EN 55022 CLASS A COMPLIANCE	7
FCC15 CLASS B COMPLIANCE	7
CE MARK	7
ABOUT THIS MANUAL	8
ABOUT GRAPHIC USER INTERFACE (GUI)	9
ABOUT MAIA XC	10
PRELIMINARY	10
GENERAL INTRODUCTION	10
FEATURES AT A GLANCE	11
MAIA XC COMPONENTS	12
VIDEOCONFERENCE TIPS	14
UPDATES AND DEEPENINGS	14
CABLING SCHEME	15
SYSTEM POSITIONING AND INSTALLATION	16
SYSTEM STATUS LED	17
KEYBOARD	18
ALPHANUMERIC KEYBOARD	19
FUNCTION-KEYS	20
OPERATION AND USE	21
MENU STRUCTURE	21
HOME PAGE	22
<i>Icons found in the GUI</i>	23
HOW TO MAKE A CALL	24
<i>Audio call modes</i>	24
Changing audio mode	24
Controlling audio	24
HOW TO MAKE A CALL FROM PHONEBOOK (“DIRECTORY” KEY)	25
DIRECT CALL	26
TO RESELECT AN INCOMING OR OUTGOING CALL	27
HOW TO RECEIVE A CALL	28

DIAGNOSTICS.....	28
PHONEBOOK	29
<i>Entering Names in the Phonebook</i>	29
<i>Modifying and Erasing Phonebook Entries</i>	29
TOOLS	30
<i>Video input management</i>	30
<i>Controlling the integrated camera</i>	30
PRIVACY FUNCTIONS	31
<i>Do not disturb</i>	31
<i>Video Privacy</i>	31
SYSTEM CONFIGURATION - SETTINGS	32
“USER” SETTINGS	32
<i>Control panel</i>	33
<i>Call-Answer mode</i>	33
General.....	33
<i>Date & Time</i>	33
<i>System Information</i>	33
“ADMINISTRATOR” SETTINGS.....	34
<i>Terminal Settings</i>	35
<i>Network interface</i>	36
IP settings	37
Addresses	37
Dynamic Ports	37
NAT	37
QoS	37
Bandwidth.....	37
H.323 settings	38
SIP settings	38
<i>Location</i>	39
<i>Load default settings</i>	39
<i>Password</i>	39
AUXILIARY INTERFACES.....	40
USB PORT	40
<i>USB hub connection</i>	40
MEMORY CARD READER	40
SYSTEM MENU.....	41
MOVING AROUND WITHIN THE PROGRAMMES.....	42
<i>The Button Bar</i>	43
“INTERNET”	44
<i>Setting the browser</i>	44
Defining the Home Page.....	44
Proxy server settings	44
“MAIL”	45
<i>Configuring the email servier</i>	45
“CHAT”	46
<i>Configuring the Network</i>	46

<i>Configuring your account</i>	46
“PHOTO VIEWER”	47
<i>Useful settings</i>	47
“FILE MANAGER”	48
“KEYBOARD”.....	49
HOW TO WRITE USING THE VIRTUAL KEYBOARD.....	49
With the mouse	49
With the arrow keys.....	49
APPENDICES.....	50
IP NETWORK REQUIREMENTS FOR VIDEOCOMMUNICATION	50
NAT – FIREWALL INTEROPERABILITY	50
TECHNICAL SPECIFICS	55
GLOSSARY	56
USE AND STORAGE CONDITIONS.....	57

SAFETY RULES

	CAUTION: for the operator's safety, only use the mains adapter that has been provided with the device.
	CAUTION: the mains cable is used as a disconnecting device, use therefore an easily accessible outlet located near the device for the power supply connection. Never remove the mains plug while the device is connected.
	CAUTION: connect the LAN port to an internal LAN circuit only. It is absolutely forbidden to connect the system to an outdoor telecommunication line.
	CAUTION: the ETHERNET cable provided with the system must be used only with this system and must not be routed under carpets, through walls, within risers, or as part of building wiring systems.
	CAUTION: connect the cable of the telephone interface to the device connector and then to the outdoor telecommunication line to avoid accidental contact with live parts of the TNV circuits.
	CAUTION: never install the system during a lightning storm.
	CAUTION: small metallic objects may be picked up by the handset receiver.
	CAUTION: This equipment will be inoperable when the mains power fails.
	CAUTION: the change from cold to hot environments can cause condensate to form inside the device. To avoid malfunctioning, wait at least 2 hours before connecting the device to the main power supply.
	CAUTION: in case of fire, do NOT use water to extinguish it.
	CAUTION: RISK OF ELECTRIC SHOCK The power supply used by this device involves lethal voltage levels.
	CAUTION: do not touch the internal parts of the device (and/or of the mains adapter).
	CAUTION: if objects or liquids leak into the device, disconnect the power supply cable IMMEDIATELY. Have it checked by an authorized technician before using the device again.
	CAUTION: contact an authorized technician/consultant for assistance.
	CAUTION: when making repairs, disconnect the device from the power supply.

PSTN WARNING

	The PSTN line can be used only in the countries of the European Union, therefore it will be disabled for all other countries.
---	---





Environmental Safety

	This equipment must not be treated as household waste and should instead be handed over to the applicable collection point for the recycling of electrical and electronic equipment. With the correct disposal of this equipment, you will help prevent any potential negative consequences for the environment and human health, which could otherwise be caused by inappropriate handling of this product. For more detailed information about recycling this product, please contact your local city office, your household waste disposal company or the dealer where you purchased this product.
---	---

State of California Prop 65 warning

	WARNING : This product contains chemicals known to the State of California to cause cancer and/or birth defects or other reproductive harm. Wash hands after handling.
---	--

Warnings

	Many of the components used in this device are sensitive to electrostatic charge.
	When handling the connection cables, disconnect the power supply and avoid direct contact with the connector terminals.
	When handling electronic components, touch a grounded surface to eliminate any static electricity. If possible, wear a grounding arm band.
	Failure to comply with these warnings could cause permanent damage to this device.

Cleaning

	To clean the device use a dry soft cloth (or with a little bit of gentle detergent). Never use solvents, such as alcohol or gasoline, to avoid damaging the finish.
---	---

Safety rules for batteries



- Risk of explosion if batteries are replaced by an incorrect battery type. Dispose of used batteries following the user instructions.
 - The batteries of this equipment must be disposed of by either a recycling company or a company qualified for the disposal of dangerous materials. The battery may also be disposed of in special recycling containers specifically for worn out battery (this may vary from country to country).
 - Only use the same type of battery that was originally provided with the equipment.
 - Replace the batteries when the remaining power charge significantly low. Do not recharge.
 - Do not use any damaged batteries.
 - Do not use the batteries for different reasons from those prescribed.
 - Do not short circuit the batteries (direct contact between + and – poles of the battery). This can happen accidentally during the maintenance of the equipment or the replacement of the worn out batteries.
 - Do not put the batteries close to flames, sparks, radiators, microwave ovens, fireplaces, direct sun light or other sources of heat. Do not throw the batteries into the fire.
 - Do not weld directly on the battery terminals.
 - Do not install the batteries with the polarity upside down. Please refer to the installation instructions for battery installation.
 - Do not damage the batteries in any way. Do not try to open or to pierce the batteries.
 - Avoid any accidental collision as it could cause the batteries to rupture and leak corrosive liquids or irritant vapours. In such case disconnect the power immediately from the equipment and batteries.
 - In case the battery liquids comes into contact with your skin or garments, wash the area immediately with water. If it comes into contact with your eyes, wash immediately with plenty of water and contact either a doctor or the nearest first aid office immediately.
- Keep away from the children's reach.

EN 55022 Class A COMPLIANCE



This is a Class A product. In a residential environment this product may cause radio interference. In such case the user may need to take adequate measures.

FCC15 Class B COMPLIANCE



This equipment has been tested and found to comply with the limits for a Class A digital device, pursuant to part 15 of the FCC Rules. These limits are designed to provide reasonable protection against harmful interference when the equipment is operated in a commercial environment. This equipment generates, uses and can radiate radio frequency energy and, if not installed and used in accordance with the instructions manual, may cause harmful interference to radio communications. Operation of this equipment in a residential area is likely to cause harmful interference in which case the user will be required to correct the interference at his own expense.

CE mark



Aethra S.p.A. hereby declares that this device complies with essential requirements and other relevant notes of R&TTE Directive 1999/5/EC. The declaration of conformity maybe obtained from:
 Aethra S.p.A. - Via Matteo Ricci, 10 -
 60126 Ancona - Italy
www.aethra.com - aethra@aethra.com

About this manual

Used symbols and syntax



Symbol related information must be followed very carefully.

Note _ **Associated instructions give useful information.**

- 1. . _ Instructions in a enumerated list must be accomplished following the reported order.
 - 2. .
-

- A) . _ The list preceded by capital letters denotes possible choices at a main level.
 - B) .
-

- a) . _ The list preceded by small letters denotes possible choices at a secondary level.
 - b) .
-

- _ The list preceded by an arrow denotes a list of possible choices.
-

- _ The list with a dot is a general list.
-

"Name" _ Words writtne in this way indicate the name of a function or a parameter present on the GUI.

"Name" _ Words written in this way indicate particular Hardware or Software functions.

NAME _ Words written in this way (and in capital letters) indicate the name of a page of the GUI (Graphical User Interface)

About graphic user interface (GUI)

Main system configurations and functionalities can be activated inside GUI (Graphical User Interface) shown on the monitor.

Main elements inside a MENU page:

HOME PAGE – main GUI page; from here you can access all system functionalities and/or configurations.

PAGE – any page inside graphic user interface (GUI).

VIDEO WINDOW – area where the image from the local and remotes cameras is visualized.

ICON – image or symbol inside a page that showing a *setting status*.

BUTTON – image inside the page that indicate a *function* that can be *activated*.

FUNCTION KEY – key linked to a button that allows an *associated function* to be performed.

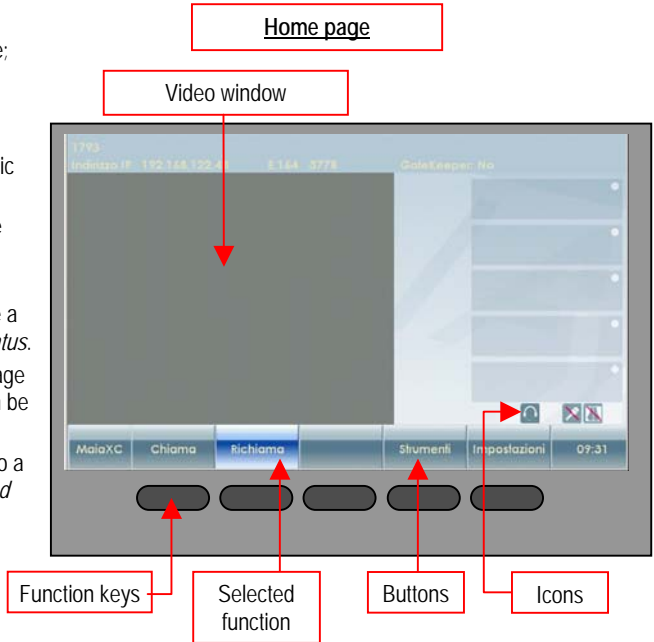

Inside a Menu you can:

PERFORM A FUNCTION – in two possible ways:

- It is possible to carry out a function assigned to a button by pressing the relative function key.
- **Select** the function desired by using the arrow key to select the right button. To **perform** the assigned function, press the OK key.

USB Mouse – When a mouse is connected to the USB port, on some pages the mouse arrow is visible. In this case, to activate a function you can click on it with the mouse.

About Maia XC

Preliminary

The System supports the complete functionality and all associated configurations that are described in this manual.

General introduction

A stylish videophone, MAIA® XC provides affordable and compact video telephony with the benefits of IP-based videoconferencing together with excellent visual and sound quality.

Versatile

IP Phone videoconferencing, Web browser e-mail Client, Photo Viewer

Multiple connectivity

Supports both SIP and H.323 protocols

Ergonomic

Ultra modern design, thin profile, easily fits into any home or office environment

Versatile Desktop Device

Provides IP telephony capabilities with IP-PBX integration, Internet browser for www pages, e-mail client and multi-protocol instant messaging for type-text communication. Photo Viewer to manage multiple type of graphics format and simple file manager.

High-Quality Video

Features a high-resolution (800 x 480 pixels, 16/9) 7" LCD video display for private discussions with top-quality images from any visual angle. A TV screen connection is also provided for applications requiring larger presentation. For video input, a built-in camera, with manual focus and automatic white balance, uses a 1/4" CCD sensor to capture business-quality, 30 fps video.

Multiple Network Connectivity

Supports both POTS and IP-based communications standards, fully conforming to the H.323 and SIP international standards with transmission rates up to 768 kbps over IP.

Features at a Glance

- Supports IP-H323 and IP-SIP networks.
- Full-duplex audio with echo cancellation.
- "Headset".
- USB 2.0 Interface.
- Interface for memory cards type SD and MMC.
- Automatic Noise Suppression.
- Remote diagnostics and management.

Maia XC components

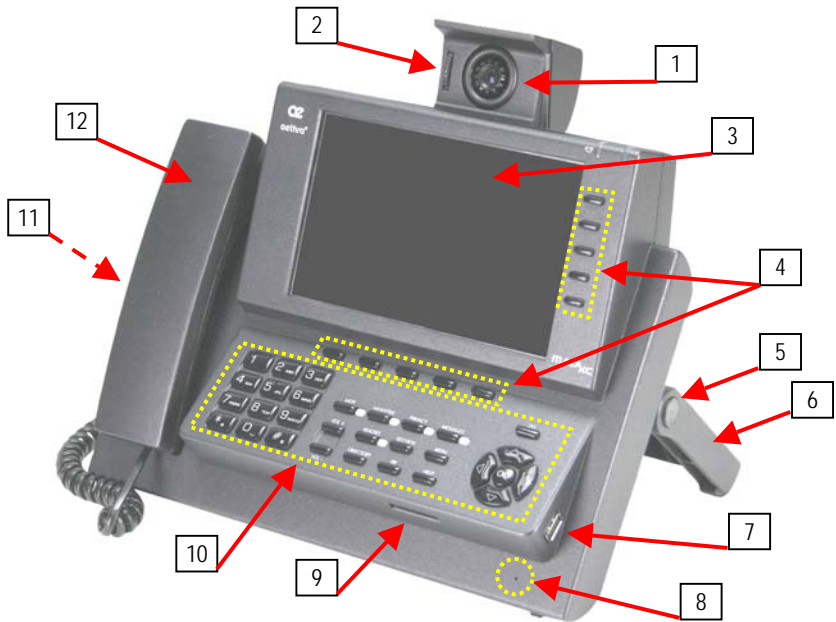

The main components of the Maia XC are:

- Codec H.320/H323, of which the main parts are:
 - 1 Video Camera.
 - 2 Tilt Video Camera.
 - 3 7" Active-Matrix LCD Display.
 - 4 Function-keys.
 - 5 Release key.
 - 6 Positionable support bar.
 - 7 USB 2.0 interface.
 - 8 Hands-Free Microphone.
 - 9 Scanning interface for Smart Card (SD, MMC).
 - 10 Keyboard.
 - 11 Speaker
 - 12 Handset.
- Power supply with cable.
- User manual.
- RJ45-RJ45 LAN cable.
- Telephone cable RJ11-RJ11.
- Packaging.

Note:

The peripherals visible in the wiring system (see relevant chapter) that are not included in the above list are included as examples only.

Video Camera

The digital colour camera can be repositioned vertically using the opposite dial. The entire camera block also slides up and down, allowing the video image to be obscured mechanically (mechanical privacy function).

Display

The digital display is a 7" LCD with 256.000 colours. The resolution is 800 x 480 pixels and has a luminosity of 350 cd/m².

Using the repositionable support bar it is possible to optimize the vertical visual angle and the contrast.

Keyboard

All videophone functionality is controlled via the numeric keypad and the buttons illustrated in the specific paragraph.

Videoconference tips

Tips to improve a virtual meeting, to optimize audio-video transmission and reception, and to fully enjoy all videoconference benefits.

Optimal Meetings

- Before starting a videoconference be sure that all you need is ready: addresses or numbers to call, lighting, microphones.
- Connect and test all peripherals eventually needed (document camera, VCR, PC/Laptop)
- Use natural gestures as in a real meeting
- Speak in your normal voice

Optimal Video

- Avoid contemporaneous usage of natural (changing) and artificial lighting
- Avoid direct artificial lighting
- Avoid "mobile" backgrounds (curtains moved by the wind)
- Try to fill the screen as much as possible with persons, not backgrounds

Optimal Audio

- Place the microphone on the table in front of people (use 2 microphones in case of big tables)
- Do not place papers or other objects in front of the microphone
- Don't rustle papers or tap on the table or microphone
- Mute the microphone before moving it.
- Speak in your normal voice

Updates and deepenings

To verify the availability of manual updates or for more information about Videoconferencing, please visit www.aethra.com

Cabling Scheme

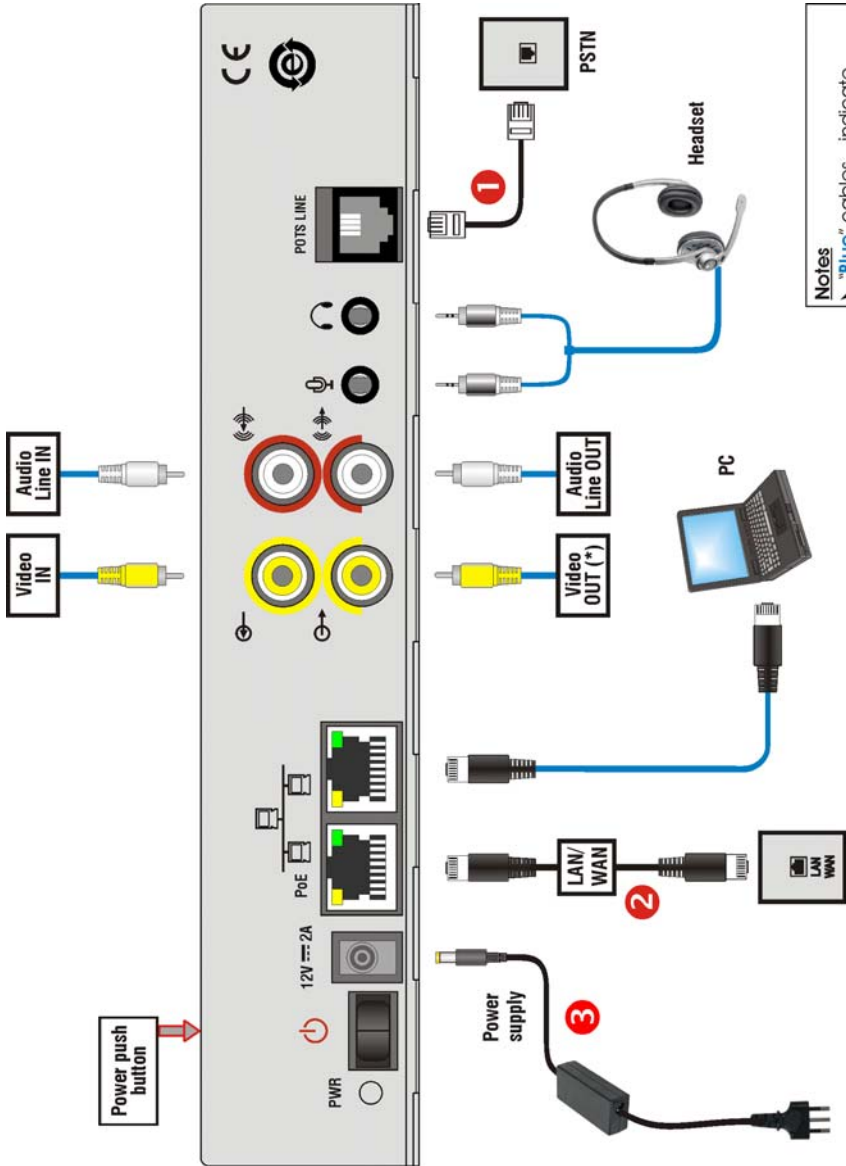

Notes

- > "Blue" cables _ indicate examples of optional cabings.
- > (*) _ function available in the next versions.

System positioning and installation



All operations must be carried out without connection to main power supply. Connection to main power supply should only be performed after complete parts assembly.

Place the system in the desired location.

Press the "Release button" **A** to tilt the videophone for improved visualization using the "Reclining support bar" **B**.



Connect the following equipment, while referring to the "Cabling Diagram":

1. Put the handset in place and connect the corresponding cable to the RJ11 socket found directly behind the screen (see picture on the right).
2. Connect the power supply (see "Cabling Scheme", cable ①).
3. Connect the LAN/WAN input to the network (see "Cabling Scheme", cable ②).
4. Connect supplementary audio or video equipments to the available inputs/outputs.
5. Press the switch on key on the System rear.
6. Wait for the main user interface to appear.

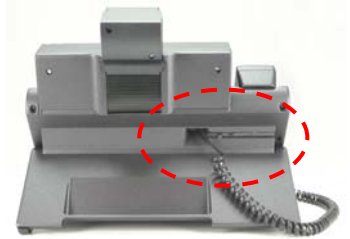



The system is now ready to use.

NB: the current SW version does not activate the PSTN telephone line (see connection diagram, cabling ③).

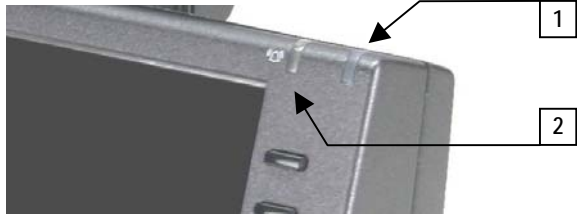
System status LED



The system status LED on the front means:

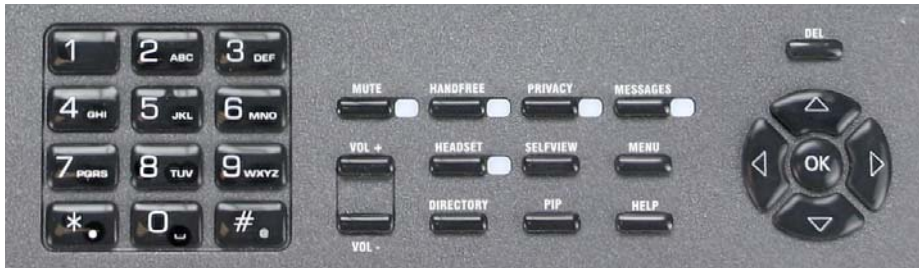

LED	LED color	Function	Status LED		
			OFF	ON	FLASHING
1	Red 	Power	System power is either off or not connected	System is on and normally operating	System power is on, but the System is in "standby" mode
2	Blu 	Incoming call indicator	No call	Call in progress	Incoming call

Keyboard



The keyboard contains a number of keys, which have a LED to indicate their status.

	<p>“Alphanumeric keys”</p> <ul style="list-style-type: none"> For letter and number insertion. (see § “Alphanumeric keyboard”).
<p>MUTE</p>	<ul style="list-style-type: none"> To activate/deactivate audio transmission. <p>Led On: indicates MUTE is active.</p>
<p>HANDFREE</p>	<ul style="list-style-type: none"> To activate/deactivate the handsfree function. Call function: sending or receiving a call. Disconnection function: end a call. <p>Led On: indicates audio is in handsfree mode.</p>
<p>PRIVACY</p>	<ul style="list-style-type: none"> Once activated the system no longer sends live video but only sends the customizable video privacy image. When system is not connected this key activates/deactivates Video privacy. <p>Led On: indicates PRIVACY mode is active.</p>
<p>MESSAGES</p>	<p>NB: Function not currently available</p>
<p>VOL + VOL -</p>	<ul style="list-style-type: none"> Audio volume control
<p>HEADSET</p>	<ul style="list-style-type: none"> Activates/deactivates external headset with microphone. <p>Led On: active audio in external headset and microphone.</p>
<p>SELFVIEW</p>	<ul style="list-style-type: none"> Activates/deactivates local video.
<p>MENU</p>	<ul style="list-style-type: none"> Enables access to the system menu.

DIRECTORY	<ul style="list-style-type: none"> Opens the phonebook.
PIP	<ul style="list-style-type: none"> Activates/deactivates PIP (PIP default position – top left-hand corner). When activated this key moves the PIP position.
HELP	NB: Function not currently available
DEL	<ul style="list-style-type: none"> For selecting from different choices in menus.
	<p>"Arrow" keys</p> <ul style="list-style-type: none"> allows navigation inside interface pages.
	<p>"OK" key</p> <ul style="list-style-type: none"> confirms selection.

Alphanumeric keyboard

Using the alphanumeric keyboard it is possible to write in the text box. When pressing each key, letters numbers or symbols appear in sequence as shown in the table below.

Particular functions and procedures:

- when it is necessary to write to letters using the same key (e.g. BA found on key 2), after writing the first letter, please wait a second before keying the second letter.
- Holding the key for longer allows the numbers to be used directly.

KEY	SYMBOLS			
1	1			
2	2	A	B	C
3	3	D	E	F
4	4	G	H	I
5	5	J	K	L
6	6	M	N	O
7	7	P	Q	R S
8	8	T	U	V
9	9	W	X	Y Z
0		0		
*	.	*		
#	@	#		

Function-keys

At the edge of the LCD screen there are 10 function-keys (5 on the right and 5 at the bottom). Their functions are the same as the buttons visualized by the on-screen menu.

The buttons on the right are assigned to addresses memorized for calls using "SpeedDial".

NB: in the current SW version the "SpeedDial" function is not active.



Operation and use

This section of the manual explains the basic functionality of the System.
It is assumed that the system is correctly installed.

Menu structure

The graphic interface has pages arranged in the following navigation tree:

- Call
- Redial
- Diagnostics (during a call)
- Tools
- Settings
 - User
 - Control panel
 - Call Answer Mode
 - Date & Time
 - System Information
 - Administrator
 - Terminal Settings
 - Network Interfaces
 - IP configuration
 - Address
 - Dynamic Ports
 - NAT
 - QoS
 - Bandwidth
 - H323 settings
 - Advanced (GateKeeper)
 - Authentication (GateKeeper)
 - SIP settings
 - Location
 - Load default values
 - Password
 - Administrator
 - User

Home Page

Once switched on, the System shows main user interface, the **“HOME PAGE”**; from here you can place a **Call**, modify system **Settings**, and control system status by means of **Status Bar**.

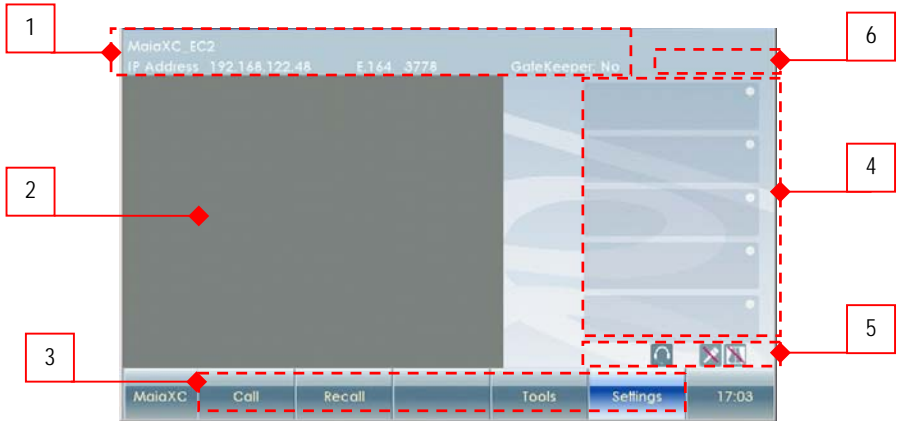





1	System Data. In this area the following information is visualized: H.323 Name – IP Address– H.323 number.
2	Video window.
3	Buttons. Can be selected using the “arrow keys” (in the example the “Call” button is selected and highlighted in blue). They can also be activate with the mouse or with the 5 “contextual function-keys” found directly below (see § “Function-keys”). The function visualized varies according to the GUI page.
4	“SpeedDial” Icons. Can be selected using the “arrow keys”. They can also be activate with the mouse or with the 5 “contextual function-keys” found on the right (see § “Function-keys”). NB: in the current SW version the “SpeedDial” function is not active.
5	In this area the icons relative to the running status of some of the Local terminal settings are found.
6	In this area the icons relative to the running status of some of the Remote terminal settings are found.

Icons found in the GUI

On the GUI pages in general there are a number of icons which provide important information about the status of some of the systems functions, or can provide help for using the GUI itself.

In **section 1** there is a LED icon which indicate the status of a channel during a call:

	Channel in startup phase		Channel synchronized
	Channel connected		Channel error

In **section 3** of the internal navigation pages the following icons are visible:

	"Back" key– Returns to the previous page		"Home" key– Returns to the Home Page
---	---	---	---

In **section 5** the following icons are visible:

	Headset active		Microphone active		Headphones active		Do not disturb
	Mute		Privacy active		Selfview active		LAN network disconnected

Other icons are described in the relative chapters.

How to make a call

There is more than one way of making a call:

- From the address book – see § “Call from Address Book”.
- Audio-Video direct – see § “Audio Video Call”.
- Call reselect – see § “Reselecting the last incoming and outgoing calls”



To make an IP call, the address of called IP terminal must be inserted following this syntax: xxx.xxx.xxx.xxx

Audio call modes

The following call modes can be performed in 3 audio modes:

- **Hands-free** – using the speaker and microphone integrated in the system. The call can be performed using the function-keys “Call”, “Recall” or the “HANDSFREE” key.
- **Handset** – on lifting the handset the call page automatically opens (see § “Direct Call”).
- **Headset** – it is possible to connect external audio devices like a Headset or separate headphones and microphone (see § “connections diagram”). When these devices are active the corresponding icon is visible on the GUI, and it is therefore possible to make the call press the “HEADSET” key.

Changing audio mode

During a call it is possible to change the audio mode in use.

The table below shows how to switch from one mode to another:

From HANDSFREE (or HEADSET) to Handset	Simply lift the handset.
From Handset to HANDSFREE (or HEADSET)	Hold down the HANDSFREE (or HEADSET) key while contemporarily replacing the handset, and then release the HANDSFREE (or HEADSET) key.
From HANDSFREE to HEADSET	Press the HEADSET key, the system will automatically switch the audio mode.
From HEADSET to HANDSFREE	Press the HANDSFREE key, the system will automatically switch the audio mode.

Controlling audio

The “VOL +” and “VOL -” keys allow you to adjust the level of received audio.

By pressing “MUTE” key you can activate the mute function, that is local audio will no longer be

transmitted. On both the local and remote displays, the icon  will appear, indicating that the mute function is active.

How to make a call from Phonebook (“Directory” key)

To enable the quick selection of a number to call, a phonebook is available to store data about terminals that are frequently called. To call one of these numbers:

1. On the keyboard press the **“Directory”** key.
2. Select the name using the “arrow keys”.
3. Activate the call using one of the following modes:
 - From the “HOME PAGE” select the function-key “Call”.
 - Lift the handset.
 - Press the “handsfree” key.
 - Press the “HEADSET” key (only if external audio devices are connected).
4. To end a call use the function-key “DISCONNECT”; the system will ask for confirmation before disconnecting the call.

Direct Call

To make a direct audio-video call, by manually inserting the IP number to call, proceed as follows:

1. Initiate the call using one of the following modes:
 - From "HOME PAGE" select function-key "Call".
 - Lift the handset.
 - Press "HANDSFREE" key.
 - Press "HEADSET" key (only if external audio devices are connected).
2. On the pages that appears insert the following data:
 - IP number to call;
 - The type of call from the drop-down menu (IP-H323, IP-SIP);
 - Select the call rate from the drop-down menu.



To select an option from a drop-down menu, it is necessary to go to the menu itself, press OK, select the desired option by means of the remote control arrows and press OK.

3. press the function-key "Call" to send the call.
4. To end the call use the function-key "Disconnect"; the system will ask for confirmation before disconnecting.

To Reselect an Incoming or Outgoing Call

From "HOME PAGE" by pressing function-key "Recall" the "Last Calls" page opens, where the following icons are visible:

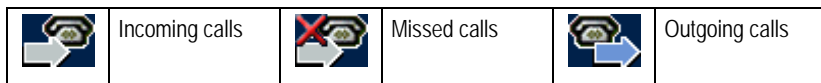

The call archive has a buffer cycle of 60 numbers.

To make a call select (with the arrow keys) the name and press the function-key "Call".

How to receive a call

When you receive a call, a notification will be displayed in a window showing the caller's number.

If the automatic answer function is not enabled, you will be asked whether or not to accept the call.

However if you are not on the main page, you will be asked to accept or reject the call whether or not the automatic answer function is enabled.

It is possible to activate an incoming call in one of the following ways:

- From the incoming call window, select the function-key **"Yes"** (the system will answer the call in **HANDSFREE** mode).
- Lift the handset.
- Press the **"HANDSFREE"** key.
- Press the **"HEADSET"** key (only if external audio devices are connected).

Diagnostics

During a call it is possible to check all the parameters of the transmission in progress by pressing the function-key **"Diagnostics"**.

Phonebook

Pressing the "DIRECTORY" key the "ADDRESS BOOK" pages opens, where it is possible to enter a new name or choose a name to call or edit an existing name.

Entering Names in the Phonebook

To enter a name:

1. Press the "DIRECTORY" key to open THE "ADDRESS BOOK" page.
2. Press the function-key "Enter".
3. Enter the data requested, use the "arrow" keys to move from one field to another, using the alphanumeric keyboard to enter the necessary data.

Note:

If you want to store an audio call only entry, you must check the Speech box.

Modifying and Erasing Phonebook Entries

To modify a phonebook entry:

1. Select the desired entry.
2. Click the function-key "Modify".
3. Enter modifications and save them

To erase an entry in the phonebook:

1. Select the desired entry and press OK.
2. Click on the function-key "Cancel" (the system will ask you to confirm deletion).

Tools

From the function-key **"Tools"**, on the **"HOME PAGE"**, it is possible to select the **video inputs** available and to activate the function **"Do not disturb"** (see § "Do not disturb").

Video input management

With this system it is possible to manage the video inputs by selecting them using the function-key **"Tools"**.

It is possible to select:

- **"Room"** – the camera integrated in the system.
- **"Doc"** – enables the entry of an external composite video signal coming from any video device (video camera, VCR etc.)

Controlling the integrated camera

For the integrated camera it is possible to manually adjust:

- Vertical panning – **A**;
- Focus – **B**;

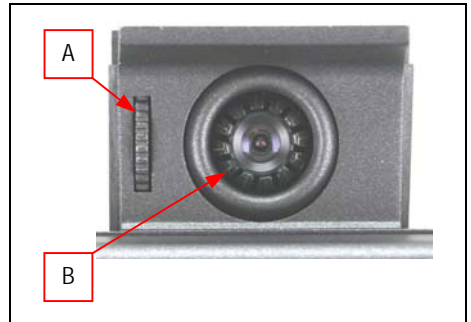

PRIVACY functions

Two PRIVACY functions are available:

- "Do not disturb"
- "Video Privacy"

Do not disturb

From the function-key "Tools" it is possible to activate the function "Do not disturb" – where for all incoming calls the system will appear busy.

For outgoing calls the function is not active.

When the "Do not disturb" function is active, this icon appears in the video window .

Video Privacy

When the system is connected.

The "PRIVACY" key activates and deactivates the dispatch of a image memorized within the system; on the remote screen only this fixed image is displayed.

When the system is not connected.

When the system isn't connected it is possible to set the **Video privacy** function– for each video connection the system will send to the remote site the video privacy image.

When the **Video privacy** function is active, in the the video window the icon  appears.

System Configuration - Settings

This section describes the procedures to properly configure the System.

Note that some configuration parameters can be modified only when no connection is active.

From the “HOME PAGE” click on the function-key “SETTINGS”, and it is possible to choose between to settings levels:

- User
- Administrator

“User” settings

From the “HOME PAGE” select:

1. **Settings**
2. **User**

From this page it is possible to access the following sub-menus:

- **Control panel**
- **Call-Answer mode**
- **Date & Time**
- **System Information**

Control panel

To access this page follow the route:

HOME PAGE / SETTINGS / USER.

On this page it is possible to activate the function **Automatic screen saver** and to set the timeout.

Call-Answer mode

To access this page follow the route:

HOME PAGE / SETTINGS / USER.

General

On this page it is possible to configure the following functions:

- **Mute:**
if selected it is active on switching on the system (also see § "Setting the audio").
It can be deactivated during a call and on disconnection is automatically reactivated.
When it is active an icon is visualized on the *local* and *remote* terminals.
- **Do not disturb:**
if selected it is active when switching the system on (also see § "PRIVACY functions").
It is not active during outgoing calls and on disconnections it is reactivated automatically.
When it is active an icon is visualized on the *local* terminal.
- **Video Privacy:**
if selected it is active when switching the system on (also see § "PRIVACY functions").
It can be deactivated during a call and on disconnection will be reactivated automatically.
When it is active an icon is visualized on the *local* terminal.
- **Confirm disconnection**
Enable/disable confirmation requests for call disconnection.
- **Automatic answer:**
Enable/disable the automatic answer function, after the selected number of rings.

Date & Time

To access this page follow this route:

HOME PAGE / SETTINGS / USER.

To configure the date and time, move the arrow key to the necessary fields and insert the data using the alphanumeric keypad.

System Information

To access this page follow this route:

HOME PAGE / SETTINGS / USER.

This section shows contains information about the software modules installed on the system, including versions, build dates, etc.

“Administrator” settings

From the “HOME PAGE” select:

1. **Settings**
2. **Administrator**

You will be prompted for a **password**.

The password is required to avoid accidental modifications and changes to settings.

The Default password value is “1234”.

From this page it is possible to access the following sub-menus:

- **Terminal Settings**
- **Network interface**
- **Location**
- **Load default settings**
- **Password**

Terminal Settings

To access this page follow the route:

HOME PAGE / SETTINGS / ADMINISTRATOR.

In this section you can configure terminal settings for various network interfaces.

It is possible to set:

- The maximum data "Rate" for a call.
- "Audio coding".
- "Video coding".

Note: With audio and video encoder/decoder settings set to <Auto> the system choose the encoder/decoder based on the connection bit rate.

Moreover you can explicitly enable/disable some functionalities, in order to have the system being compatible with old systems.

The functions available are:

- G.722.1
- H.264
- H.263 Annexes

Network interface

To access this page follow the route:

HOME PAGE / SETTINGS / ADMINISTRATOR.

A page will be visualized where it is possible to set some parameters of the network interface usable from the system.

The configurable pages are:

- IP Configuration
- H.323 settings
- SIP settings



For configuration information, please contact your network administrator.

IP settings

This menu is for Integrated LAN configurations:

- Address
- Dynamic Ports
- NAT
- QoS
- Bandwidth

Addresses

In this menu, you can enable/disable automatic assignment of an IP address (Automatic IP address), or insert manually:

- IP Address;
- SubNet Mask;
- Gateway IP Address ;
- DNS Server IP Address.

Dynamic Ports

The range of the TCP and UDP (*) "Dynamic Ports" can be found automatically (Auto detect) or set manually (default: TCP-3230; UDP-3230).

Note (*):

When a firewall is crossed, the firewall administrator must open a range of dynamic TCP and UDP ports, as configured in the system, to allow bidirectional IP traffic. Moreover, once the ports have been opened, the protocols (TCP 1720 (Q.931), TCP 1503 (T.120), UDP 1719, and 1718 (RAS)) involved in a call must be taken into account.

NAT

In default "Use NAT" is already selected, and the following parameters can be set:

- a) "NAT Type";
- b) "Public IP Address" must be the public IP address of the NAT;
- c) "Refresh Time".

QoS

It is possible to choose the policy regarding "Quality of Service" (QoS) by choosing between Precedence/TOS and Service Diff.

Bandwidth

If the function is "Activated" it is possible to set maximum limits for the use of bandwidth (in Kbps). These limits can be different for reception and transmission.

H.323 settings

This section contains the configuration options necessary to use the system with the H.323 protocol:

- **Name H.323:** (H.323 ID) the name used by the terminal for registration with the GateKeeper.
 - **Number H.323:** (E.164) identifying number used by the terminal for registration with the GateKeeper.
 - **Use GateKeeper:** Use or not of a GateKeeper.
It is possible to set the following parameters:
 - **Automatic IP Address.**
 - **IP Address** – insert IP address.
 - **Use H.460.**
 - **Advanced:**
"Auto Registration" to the GateKeeper, allows the modification of the registration time limits (**Regist. Expiration Time**, default: 90 sec);
"Registration Interval Time" (default: 10 sec).
 - **Authentication:** with "Enable" the authentication criteria for the server GateKeeper is activated, for which it is necessary to insert the parameters requested:
"Mode" – "GateK. ID" – "User Name" – "Password".
- NB: to use the GateKeeper it is important that the local terminal is set in the same time zone as the server GateKeeper.**
- **Using NetMeeting:** If a T.120 connection is available, a data conference using NetMeeting can be started by entering the IP address of the application host server. To enable this function:
 - Check the box next to "Use NetMeeting"
 - Enter a server **IP address** where the application is hosted.

SIP settings

This section contains the configuration options for use of the system with the SIP protocol:

- Terminal "**Name**"
- Terminal "**Password**"
- "**Use registrar**": run terminal registration at a SIP Registrar Server.
"Server": Enter SIP Registrar Server IP address.
- "**Use Proxy**": use a Sip Proxy Server.
"Server": Enter Sip Proxy Server IP address.
- "**TCP**" - "**UDP**": use the appropriate protocol.
- "**Port**": Port for server signaling (Default is 5060).

Location

To access this page follow the route:

HOME PAGE / SETTINGS / ADMINISTRATOR.

This section contains regional data about the terminal:

Terminal Name: Enter a name for the terminal

Country Name: Select the country. An international country code will be automatically provided.

Language: Select the desired language.

PBX: Enter the PBX access number for an outgoing call.

Audio Coding: Select the type of audio encoding in "Transmission."

Video Standard: Select the video standard (PAL/NTSC), depending on the peripheral connected to Video Out.

Selection Tone: Select the desired tone.

Load default settings

To access this page follow the route:

HOME PAGE / SETTINGS / ADMINISTRATOR.

From here, the default System configuration can be reloaded. There are two options:

- "User settings only"
- "Factory Defaults".

If the "FACTORY SETTINGS" option has been chosen, users will be asked, as a precaution, for confirmation. An affirmative answer will result in the factory settings being reloaded. All user settings and data will be lost, including call history, phonebook numbers and static IP addresses.

Password

To access this page follow the route:

HOME PAGE / SETTINGS / ADMINISTRATOR.

There are two different kinds of passwords:

Administrator password: Always active. Can be modified by pressing the "EDIT" icon.

User password: Must be activated. Can be modified by pressing the "EDIT" icon.

You can access "Settings" page only.

Note: The Default password value is "1234".

Auxiliary interfaces

The Maia XC offers the following auxiliary interfaces:

- USB 2.0 Port
- Memory card reader type SD (Secure Digital) and MMC (Multi Media Card).

USB port

It is possible to connect to the USB port Plug&Play interfaces such as mouse, keyboard, pendrive, hub.

USB hub connection

It is possible to connect a hub in order to have more than one USB interfaces connected contemporarily.

!	<p><u>Combined connection of MOUSE and KEYBOARD.</u></p> <p>WARNING – if the connection is made while the system is switched on, please follow the connection sequence below:</p> <ol style="list-style-type: none">1. Hub with Maia XC2. Mouse with Hub3. Keyboard with Hub
----------	---

Memory card reader

The memory card normally contains images that can be viewed using the programme "Photo Viewer"; in addition the contents of the memory card are also visible using the programme "File Manager".

System Menu

On pressing the "Menu" key, a window appears where it is possible to select the desired programme:

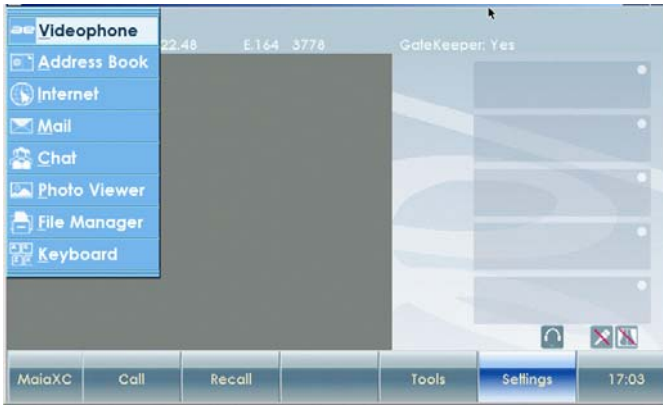

Videocommunication programs

- "Videophone" – the management programme for the Videophone, used to carry out calls and to configure the system settings.
- "Address Book" – accesses the address book.

Additional application programs (described in later chapters)

- "Internet" – opens the browser for Internet use.
- "Mail" – programme that manages emails.
- "Chat" – programme for using chat.
- "Photo Viewer" – programme to view photos.
- "File Manager" – programme to manage the system's internal files.
- "Keyboard" – programme that visualizes and allows the use of a virtual onscreen keyboard.

Moving around within the programmes

Inside the programmes it is possible to **activate** the various functions using:

- The **function-keys** that appear in the apposite bar (see § “The Button Bar”);
- The **arrow pointer**  can be managed: from the GUI in combination with the **OK** key,
> from the **MOUSE** – if this has been installed (**recommended**),
> from the system **KEYBOARD** – to move the pointer:
 - a) press the function-key “**Pointer**” (to activate the function),
 - b) use the arrow-keys to move the pointer;

To run the **cursor** through the vertical slide bar, proceed as follows:

With the arrow-keys on the keyboard

1. Place the pointer in the **non-active** part of the bar, see example on the right;
2. press OK.

With the mouse

1. Place the pointer in the **non-active** part of the bar, see example on the right;
2. Click with the left mouse button;

or

1. Place the pointer **on top** of the cursor;
2. Hold down the left button of the mouse and drag the cursor to the desired position.

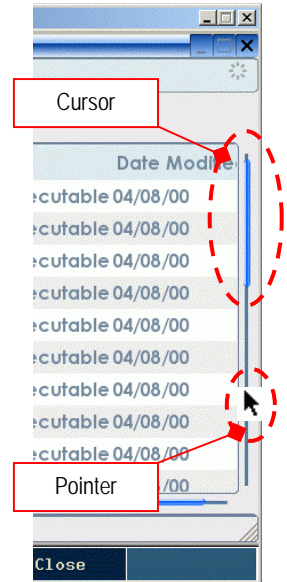

The Button Bar



The button bar below is for moving within the graphic interface of the programme being used. It is visualized when the following programmes are used:

Internet – Mail – Chat – Photo Viewer – File Manager.

The buttons can be:

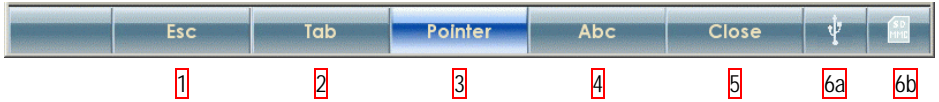
- Selected with the “arrow-keys” (in the example the “**Pointer**” button is selected and highlighted in blue).
- Activated by the mouse or using the 5 “contextual function keys” directly beneath.



1	Not used
2	To move among the various fields and icons found on the present page.
3	Activate the arrow-pointer  when it must be managed by the arrow-keys on the keyboard. To move the pointer, press the arrow-keys; when the pointer is on an active field or icon, press OK to activate the function.
4	Selector of the writing settings on the alphanumeric keyboard. Abc – first letter of a sentence in upper case. abc – all letters in lower case. ABC – all letters in upper case. 123 – only numbers.
5	Close the programme windows.
6a	In these fields the symbols that indicate the activation of particular applications in visualised:  – Indicates the presence of an active USB interface.  – Indicates the presence of an SD or MMC memory interface.
6b	

“Internet”



This is the application for using the Internet. The “Start Page” is www.google.it.

The “Home Page” is not predefined. To define the “Home Page” see § “Defining the Home Page”.

Setting the browser



Defining the Home Page

To define the “Home Page” proceed as follows:

1. Click on the icon  and select “**Preferences**”, the page “**Minimum Preferences**” will open;
2. click on the icon , the “**General**” page will open where you can write the name of the preferred Home Page (e.g. www.aethra.com);
3. click on the icon “**Save**”.

Proxy server settings

If it is necessary to configure the Proxy server, proceed as follows:

1. Click on the icon  and select “**Preferences**”, the page “**Minimum Preferences**” will open;
2. click on the icon , the “**Network**” page will open where you can write the address of the Proxy server port;
3. click on the icon “**Save**”.

“Mail”

Using this programme it is possible to manage your own email account.
In order to use it, the email server must be configured.

Configuring the email servier



To configure these parameters please contact your network administrator.

The first time the programme is opened the wizard installation guide automatically opens, then proceed as follows:

1. First page “**Welcome to Sylpheed-Claws**” – press “**Forward**”;
2. Page “**About You**”: insert the personal data of your own email address (e.g. – name: *maiaxc* / email address: *maiaxc@aethra.com* / organization: *AE*) – to proceed press “**Forward**”;
3. Page “**Receiving mail**”: insert the data supplied by your IP provider, (e.g. – Server type: *POP3* / server address: *sirmail.vnet.aethra.it* / username: *maia* / password: *123456*) – press “**Forward**”;
4. Page “**Sending mail**”: insert data supplied by your IP provider, (e.g. – SMTP server address: *smtpop.albacom.net*) the “**Use authentication**” function is not essential, – press “**Forward**”;
5. Page “**Security**”: if you want to use the safety protocol SSL, check the relative box; – press “**Forward**”;
6. Page “**Configuration finished**”: to conclude the configuration and save it, press “**Save**”, the email programme page will then open.

It is possible to modify an email account or create a new one from the “**Configuration**” menu.

“Chat”

In order to chat with remote users it is necessary to initially configure the programme.

It is not possible to send or receive file using chat.

When you select Chat from the system Menu, in the main window the **“Buddy List”** from where it is possible to carry out all the programme functions.

Configuring the Network



For the configuration of these parameters please contact the network administrator.

1. **“Buddy List”** window: open the **“Tools”** menu and select **“Preferences”**;
2. **“Preferences”** window: open the **“Network”** folder and set the following parameters:
set **Autodetect IP address** or **Public IP** (if you have a fixed IP),
Proxy Server – if you use a Server Proxy, set the type and if necessary the IP and the port;

Configuring your account

In order to use the chat it is necessary to configure your account:

1. **“Buddy List”** window: open the **“Accounts”** menu and select **“Add/Edit”**;
2. **“Accounts”** window: press **“+Add”**;
3. **“Add Account”** window: insert the following parameters in to the **“Basic”** folder:
Protocol – choose the protocol which corresponds to the chat area you require (e.g. – *MSN*),
Screen name – insert the email that will be visualised,
Password – insert a password – to avoid re-inserting the password it is possible to select the check box **“Remember password”**,
Local alias – insert the alias that will be visualised during the chat;
4. **“Add Account”** window: in the **“Advanced”** folder, insert the following parameters:
Proxy Options / Proxy Type – insert the same data as in the configuration of the **“Network”**;
5. **“Add Account”** window: click on **“Save”** to save your account;
6. **“Accounts”** window: press **“Close”**;

“Photo Viewer”

“Photo Viewer” is a simple and intuitive programme for viewing and managing images. It is not possible to edit or modify the images.

Useful settings

For a better use of the programme, use of the mouse is recommended.

For a better visualisation of the image preview withing the main page, it is useful to set the configuration “Fit image to window”:

1. From the main page press the icon “Configure options”; 
2. From the “Preferences” page, in the “Image” folder select “Fit image to window”.

If you wish to see a “full-screen” image (in a new window), click on the right mouse button on the image and select “View in new window”.

“File Manager”

This is the programme with which it is possible to manage the folders and the files inside the system.

It is practically the same as the file management used in normal computers.

The image below illustrates the main page, whose visualisation structure can be personalised using the options contained in the “View” menu.

The main page can be viewed as below (depending on how you wish to configure the GUI):

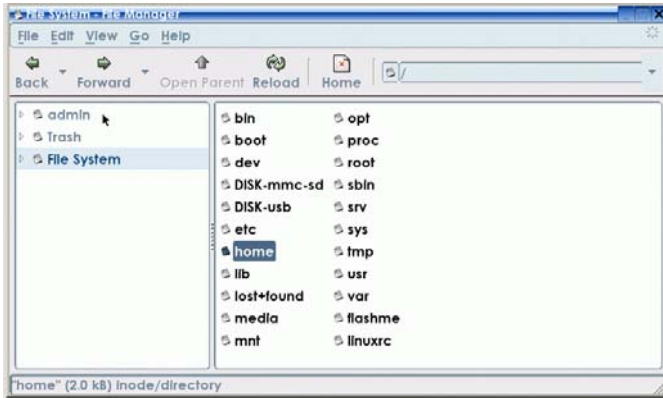

In the window on the left the list of folders is visualised. In the window on the right the contents of the selected folder are visualised.

The main folders are:

- “**admin**” – this folder is directly managed by the user. Only in this folder is it possible to create or delete new folders or files.
It is visualised at the same level as the other two main folder to make it easy to access, however the real location of the folder is under: “File System/home”.
- “**Trash**” – the folder where the files and folders to be deleted are placed.
Remember to empty this folder to avoid occupying memory space.
- “**File System**” – this folder contains all the Operating system folders, but above all it contains the folders for the management of the memory interface connected to the memory card reader (DISK-mmc-sd) and the USB port (DISK-usb).

“Keyboard”

Inside the additional application programmes it is possible to utilize a virtual keyboard.

To activate the keyboard:

1. press the “Menu” key;
2. from the system’s menu list select “Keyboard”
the keyboard is visualised over the program window (see image below);

With the mouse it is possible to move the keyboard to the desired position.



If it is necessary to visualise the entire program window, close the keyboard.

How to write using the virtual keyboard

With the mouse

For an optimum use of the virtual keyboard use of the mouse is recommended.

1. Click with the mouse in the space where you wish to write (the text cursor will be activated);
2. Use the mouse to select the desired letters on the keyboard.

With the arrow keys

1. Move the arrow key to the space where you wish to write and press OK (the text cursor will be activated);
2. Move the arrow key over the keyboard and press OK when on the required key.

Appendices

IP Network Requirements for Videocommunication

The network requirements for point-point connections between IP videoconferencing terminals are as follows.

The complete network path connecting two IP terminals must have a constant available bandwidth for the whole duration of the connection. The effective bandwidth used on LAN/WAN Full-Duplex network connections is equal to the sum of the Audio Rate and Video Rate, plus approximately 20% for TCP/IP overhead.

In the case of Half-Duplex LAN/WAN networks, the aforementioned bandwidth is doubled. For example, if it is necessary to guarantee a 384K connection for the video and a 64K for the audio, the bandwidth allocated must be at least $(384+64) * 1.2 \approx 540K$ for each Half-Duplex connection. In case of dial-up WAN links, it should be underlined that their efficiency in terms of "useful" bandwidth is approximately half the total available bandwidth.

It is always preferable to use mechanisms such as QoS for WANs because they take into account the total bandwidth required for a videoconference, rather than relying exclusively on over-dimensioning the network. This is necessary for the handling of increasing numbers of simultaneous connections or a network that is already loaded.

The network needs to be set up so that latency and jitter are as low as possible. Extended times for latency and variable jitter can create serious problems, especially in video quality.

It is always preferable for IP terminals to be connected to switched type LAN connections to avoid the traffic generated by terminals being superposed on the normal traffic present on the network.

It is preferable to avoid using NAT-type protocols on router interfaces that route IP packets, since NAT protocols often do not allow the correct routing of connections.

If NAT, firewall or access list implementations are to be used, they must be IP compatible.

NAT – FIREWALL Interoperability

Introduction

There are many strategic advantages for companies that succeed in making all traffic converge from voice applications, video and data to one IP network infrastructure.

Unfortunately, the drive to concentrate all IP communications onto one single network has reduced. The connection between a company's corporate network and the Internet world is accomplished with firewalls and devices using NAT (Network Address Translation), which block voice and video calls via IP. Firewalls block IP traffic for video and voice by preventing any unsolicited communication from the outside. Devices implementing NAT block IP traffic because all equipment on the internal network uses private IP addresses, and can therefore not be contacted from outside the local domain.

There are several solutions to the problem of getting IP communications past NAT and firewalls: bypassing the firewall or NAT device, upgrading the network infrastructure with an Application Level Gateway (ALG), and going out through the firewall or NAT using semi-tunneling connections.

Going around the firewall or NAT device is not the best solution for most companies. Removing the firewall or placing videoconferencing equipment on an unshielded section of the network could seriously compromise the network's security.

Using these devices is very expensive and besides this an access policy for Firewalls and NATs would be needed. These devices should be located along the communication path at every point where a NAT and

Firewall are present.

A second solution is the improvement of the network by the introduction of an ALG, but this is intrusive and potentially expensive. ALGs are software packages specifically designed for firewalls from various producers that examine every packet attempting to pass through the firewall in order to determine whether it concerns a known protocol like H.323 or SIP. If the packet contains a known protocol, the Firewall allows it through. However, like Proxies and MCUs that go around firewalls, ALGs also need an access policy for firewalls and every firewall or NAT device needs up-to-date ALG software. Because new protocols are continually being developed, ALG software must be updated frequently.

IP Voice and Video Crossing NAT and Firewall

The use of existing network infrastructures for the transmission of voice, video and data promises interesting strategic advantages for companies of all sizes. Commonly known as “rich media communications” or “Internet Protocol (IP) communications” these technologies for converging networks offer new opportunities to communicate, coordinate and collaborate with customers, suppliers, commercial partners and others all over the world.

Unfortunately, the protocols used for IP communications conflict with most of the security mechanisms for networks (such as Firewalls and NAT), resulting in protracted or late implementation times for IP video and voice applications.

Firewalls and NATs – How they work

In an IP network, every device is assigned a unique IP address. All computers, telephones, and videoconference terminals have at their disposal approximately 65,000 ports for the purpose of establishing communication channels to transmit data to other devices on the network.

Messages between IP network devices are composed of packets that contain the following information: the IP address of the terminal that has generated the message, the port number from which the message has been sent, the IP address of the destination terminal, the port number at the destination, and the data being sent.

Firewalls

Companies that allow connection to the Internet by their employees typically install a firewall in order to prevent external access of or tampering with internal data.

The firewall examines the destination IP address and port number of every packet received from outside. Usually, firewalls are configured in such a way that if a computer from inside the firewall requests data from a computer outside the firewall, the response packets will be allowed through from the external computer, but only if they are sent to the IP address and port of the internal computer that generated the request.

If the Firewall receives a packet destined for a computer that is located internally and determines that the destination computer has not initiated any communication, the firewall discards the incoming packet.

Firewalls are nearly always configured to block all incoming traffic that has not been explicitly requested. Internal web servers are the exception: they must be accessible from the outside. To allow this, the network administrator configures the Firewall to let through packets destined for port 80 of the IP address of the web server. This operation allows external users to send requests to connect to the company's web server in order to access data on that server.

NAT (Network Address Translation)

Network Address Translation is an Internet standard that allows a LAN (Local Area Network) to use a set of IP addresses for internal traffic and another address (or set of addresses) to connect to services on an external network (the internet, for example). Devices that implement NAT are located at boundaries between the LAN and the external network, and their purpose is to provide translation of IP addresses for all packets that are destined for the external network. Many organizations use NAT as a security mechanism because it masks the internal IP addresses—if hackers do not know the IP address of a machine, they cannot attack it and cause disruptions. NAT also allows a company to use more IP addresses than they might otherwise be allocated. Since these addresses are only used internally, there is no problem with IP address conflicts with other organizations.

Problems with Video and Voice Communications on NAT/Firewall Protected Networks

The IP based voice and video protocols like H.323 require that terminals be capable of establishing audio-video communication channels using IP addresses and data ports. In this situation, a problem arises: terminals must “listen” for incoming calls to establish IP connections, but the firewall is generally configured in such a way as not to allow packets past that are not expressly requested. Even if the network administrator left a port open for the terminal to receive notification of a call (port 1720, designated as a “well-known TCP port”) the video and voice communication protocols for IP necessitate the opening of other ports in order to receive control messages and open audio and video channels.

The identities of these additional ports are determined dynamically, not in advance, meaning that the network administrator would have to open all the firewall ports to allow video and voice communication, thus virtually disabling the firewall. Network administrators are unlikely to do this (and wisely so), since it effectively eliminates network security policies. NAT also creates an obstacle for voice and video communications over IP. NAT allows an organization to assign private IP addresses to machines on the local network, but routers that control the flow of data towards the Internet can handle only packets with routable addresses or public IP addresses.

A terminal located behind the NAT device on the LAN can initiate communication with any other terminal in the same LAN because the IP addresses within the LAN are routable, meaning that it is possible to have subnets in a company managed by an internal router. This allows the establishment of audio-video communications on different branches of the subnet.

Because they have private addresses, and are therefore not accessible from outside the NAT, terminals on the LAN cannot be reached by externally originating calls. Even if they initiate calls to external terminals, a problem still arises. When the call is initiated, the IP address of the calling terminal is contained in the payload of the packet sent. The destination terminal receives call setup packets, examines them and starts to transmit audio and video towards the terminal from which the call was received, and from which the IP address was obtained by examining the contents of the received packets. If this IP address is private, the router for Internet access discards the audio and video packets sent from the terminal external to NAT towards the internal terminal because the packets sent were non-routable. The connection between two terminals appears to be successful but in reality the NAT-internal terminal never receives the audio or video from the external terminal.

Solution for the NAT/Firewall Problem

The only equipment that does not create any of the problems described above is a NAT/firewall H.323-compatible device. Such a firewall does not block the TCP 1720 port and allows access to the other, dynamically-determined H.323 ports.

Videoconferencing systems usually have private IP addresses that are not accessible from external routers. To allow calls to function properly, the network administrator can define static NAT (a permanent

association between a private IP address and a public IP address reserved for H.323 videoconferences) for every terminal that must be accessible from an external connection.

The NAT device substitutes the static IP address in the payload and header setup packet sent from the internal terminal to the external terminal. The destination terminal uses that address for addressing the reply packets, which are routed through the NAT device to the internal terminal.

Firewall ALG

Application Level Gateways (ALGs) are firewalls programmed to recognize specific IP protocols like H.323. Instead of looking only at the information contained in packet headers to determine whether to transmit or block packets, ALGs analyze in detail the data contained in the payload packet. The H.323 protocol inserts important control information such as audio and video port identification in the payload packets. The terminal expects to receive audio and video connections from the remote calling terminal on these ports. By analyzing which port the terminal expects to use, the ALG dynamically opens only those ports, leaving the others closed to preserve network security. An example of a firewall ALG follows.

The Aethra Application Level Gateway is present in the Aethra Stargate xDSL Router and allows any videoconferencing terminal, independent of its manufacturer, resolve the NAT/firewall problem. The Stargate router is capable of checking every incoming and outgoing H.323 call and dynamically opening only the ports being used for the H.323 videoconference.

The Stargate router also supports NAT functionality and is therefore capable of substituting the public NAT address for the private IP address automatically inserted in the H.323 payload packets by the internal terminal. When the Aethra ALG functionality is used with an Aethra videoconferencing system, the "Aethra NAT" function of the videoconferencing system must be disabled because the network equipment is H.323 compatible.

Technical specifics

<p>Supported Standards</p> <ul style="list-style-type: none"> ITU-T H.323 v4: IP networks IETF-SIP (RFC3261): IP networks Video : H.261, H.263+, H.264, Audio : G.711, G.722, G.722.1 Annex C, G.728, MCU compatibility: H.243 <p>Transmission</p> <ul style="list-style-type: none"> Bit rate: 64 kbps ÷ 768 kbps (H323/SIP) <p>Video</p> <ul style="list-style-type: none"> Frame rate (Tx/Rx): 25 fps PAL 30 fps NTSC Video resolution: <ul style="list-style-type: none"> FCIF 352 x 288 pixels QCIF 176 x 144 pixels 4CIF 704 x 576 pixels for still images (Annex D H.261) SIF 352 x 240 pixels QSIF 176 x 120 pixels 4SIF 704 x 480 pixel for still images (Annex D H.261) Remote camera control H.281 (H.323) <p>Audio</p> <table border="1"> <thead> <tr> <th>Audio</th> <th>Band</th> <th>Bit rate:</th> </tr> </thead> <tbody> <tr> <td>G.711</td> <td>300 ÷ 3400 Hz</td> <td>48/56/64 kbps</td> </tr> <tr> <td>G.728</td> <td>50 ÷ 3400 Hz</td> <td>16 kbps</td> </tr> <tr> <td>G.722</td> <td>50 ÷ 7000 Hz</td> <td>48/56/64 kbps</td> </tr> <tr> <td>G.722.1</td> <td>50 ÷ 7000 Hz</td> <td>24/32 kbps</td> </tr> <tr> <td>G.722.1 Annex C</td> <td>50 ÷ 14000 Hz</td> <td>24/32/48 kbps</td> </tr> </tbody> </table> <ul style="list-style-type: none"> Echo cancellation Full-duplex Adaptive post filtering Automatic Gain Control (AGC) Automatic Noise Suppression <p>Built-in Camera</p> <ul style="list-style-type: none"> Format 4:3 Digital 8bit Picture elements PAL 542 x 586 pixels NTSC 542 x 496 pixels Resolution 380 TVL / 470 TVL Focus Manual White balance Automatic Minimum illumination 0.5 lux S/N 52 dB Manual Tilt 	Audio	Band	Bit rate:	G.711	300 ÷ 3400 Hz	48/56/64 kbps	G.728	50 ÷ 3400 Hz	16 kbps	G.722	50 ÷ 7000 Hz	48/56/64 kbps	G.722.1	50 ÷ 7000 Hz	24/32 kbps	G.722.1 Annex C	50 ÷ 14000 Hz	24/32/48 kbps	<p>Built-in Display</p> <ul style="list-style-type: none"> Type TFT LCD 16/9 256K Color Size 7" Resolution 800x480 pixels Touch Screen (Factory Option) <p>Network Interfaces</p> <ul style="list-style-type: none"> Ethernet 2-port switch 10/100 BASE-T (2xRJ45) RJ11-type single line analog on PSTN WiFi Module 802.11b&g (Factory Option) <p>Audio/Video Interfaces</p> <ul style="list-style-type: none"> Video Inputs <ul style="list-style-type: none"> Main Camera Integrated 1x Composite RCA Video Outputs <ul style="list-style-type: none"> Main Monitor Integrated LCD 7" 1x Composite RCA Audio Inputs <ul style="list-style-type: none"> Mic Integrated Handset RJ11 1x Line In RCA Headset 3.3 mm jack Audio Outputs <ul style="list-style-type: none"> Speaker Integrated Handset RJ11 1x Line Out RCA Headset 3.5 mm jack <p>Auxiliary Interfaces</p> <ul style="list-style-type: none"> USB 2.0 (A) master High Power Memory Card Reader SD, MMC <p>User Interface for Videoconferencing</p> <ul style="list-style-type: none"> Multilingual on-screen graphic user interface: User selectable languages: Italian, English, French, Spanish, German, Portuguese, Norwegian, Swedish, Russian, Czechoslovakian, Hungarian, Polish, Finnish, Simplified Chinese, Traditional Chinese, Japanese, Korean Diagnostics and management functions Call progress monitoring Customizable Graphic User Interface 	<p>Built-in hands free</p> <ul style="list-style-type: none"> Electric omni directional microphone Speaker 8 Ohm 0.5 Watt <p>Security</p> <ul style="list-style-type: none"> AES encryption standard 128 bit for multimedial streams H.235 (H.323), MD5 (SIP) NIST (National Institute of Standards & Technology) certified <p>Add On</p> <ul style="list-style-type: none"> Internet Web Browser Feed RSS Email Client IMAP, POP3 Multi-Protocol Instant Messaging Manager compatible with: Windows Live™ Messenger, Google™ Talk, Yahoo® MSG, IRC File Manager Photo Viewer supported format: wbmp, jpg, ani, bmp, gif, ico, pcx, png, pnm, ras, tga, xbm, tif, xpm, svg <p>Telephony Features</p> <ul style="list-style-type: none"> Audio & Video Privacy Auto-Reply Selectable Ring Tones In-band DTMF Speed Dial Last Number Redial Call Logging Pulse/tone calls (POTS only) <p>Web management</p> <p>All the configuration, call, diagnostics and management functions are accessible using the following web browsers: Microsoft® Internet Explorer™, Netscape Navigator™.</p> <p>Remote Diagnostics and Management</p> <table border="1"> <thead> <tr> <th></th> <th>Local</th> <th>Web Browser</th> <th>SNMP</th> </tr> </thead> <tbody> <tr> <td>Self test</td> <td>Yes</td> <td>Yes</td> <td>Yes</td> </tr> <tr> <td>Diagnostics</td> <td>Yes</td> <td>Yes</td> <td>Yes</td> </tr> <tr> <td>Configuration</td> <td>Yes</td> <td>Yes</td> <td>Yes</td> </tr> <tr> <td>Call</td> <td>Yes</td> <td>Yes</td> <td></td> </tr> <tr> <td>Error tracking</td> <td>Yes</td> <td>Yes</td> <td>Yes</td> </tr> </tbody> </table> <p>Power Supply</p> <ul style="list-style-type: none"> 12V, 2Amp max Power Over Ethernet (IEEE 802.3af) (Factory Option) <p>Dimensions</p> <ul style="list-style-type: none"> MAIA XC Width 30.3 cm (11.93") Height 23 cm (9.05") camera closed 28cm (11.02") camera open Depth 10 cm (3.93") Depth 1.950 Kg (4.31 lbs) 		Local	Web Browser	SNMP	Self test	Yes	Yes	Yes	Diagnostics	Yes	Yes	Yes	Configuration	Yes	Yes	Yes	Call	Yes	Yes		Error tracking	Yes	Yes	Yes
Audio	Band	Bit rate:																																										
G.711	300 ÷ 3400 Hz	48/56/64 kbps																																										
G.728	50 ÷ 3400 Hz	16 kbps																																										
G.722	50 ÷ 7000 Hz	48/56/64 kbps																																										
G.722.1	50 ÷ 7000 Hz	24/32 kbps																																										
G.722.1 Annex C	50 ÷ 14000 Hz	24/32/48 kbps																																										
	Local	Web Browser	SNMP																																									
Self test	Yes	Yes	Yes																																									
Diagnostics	Yes	Yes	Yes																																									
Configuration	Yes	Yes	Yes																																									
Call	Yes	Yes																																										
Error tracking	Yes	Yes	Yes																																									

Glossary

AACLD Advanced Audio Coding Low Delay
AES Advanced Encryption Standard
AGC: Automatic Gain Control.
BRI Basic Rate Interface
CD Collision Detection
CE Communitée European
CIF Common Intermediate Format
CLIR Calling Line Identity Restriction
CODEC Coder/Decoder
COLR Connected Line Identity Restriction
CRC Cyclic Redundancy Checking
CSU Channel Service Unit
CTS Clear To Send
DHCP Dynamic Host Configuration Protocol
DTR Data Transfer Rate
DVI (-I) Digital Video Interface (integrated)
IEC International Electrotechnical Commission
IP Address Internet Protocol Address
ISDN Integrate Services Digital Network
ISP Internet Service Provider
LAN Local Area Network
MCU Multi-point Control Unit
MIC Microphone
MSN Multiple Subscriber Number
NAT Network Address translation
NR Noise Reduction
NSF Non Standard Facility
NT Network Termination
NTSC National Television Systems Committee
PABX Private Automatic Branch Exchange

PAL Phase Alternation Line
PBX Private Branch Exchange
PC Personal Computer
PiP Picture-In-Picture
PRI Primary Rate Interface
QCIF Quarter Common Intermediate Format
QoS Quality of Service
Router A device that attaches two or more network devices and forwards data accordingly.
RTS Ready To Send
SIF Source Input Format
SNMP Simple Network Management Protocol
SPID Service Provider Identification
SQCIF Sub-Quarter Common Intermediate Format
SVGA Super Video Graphics Array
TCP/IP Transmission Control Protocol/Internet Protocol
TCS Terminal Control String
TOS Type Of Service
TTL Time To Live
UDP User Datagram Protocol
UL Underwriters Laboratories
VCR Video Cassette Recorder
VGA Video Graphics Array
VISCA Video System Control Architecture
VNC Virtual Network Computing
WAN Wide Area Network
XGA Extended Graphics Array

USE AND STORAGE CONDITIONS

OPERATING TEMPERATURE	0°C ÷ +40 °C
RELATIVE OPERATING HUMIDITY	10% ÷ 93 % (without condensation)
STORAGE TEMPERATURE	-40 ÷ +70 °C

REFERENCE REGULATIONS (CE MARK AND RELIABILITY TESTS)

STORAGE	EN 60068-2-1 Test Ab (IEC 60068-2-1) EN 60068-2-2 Test Bb (IEC 60068-2-2)
TRANSPORTATION	IEC 60068-2-32 Test Ed - Method 1 IEC 60068-2-64 Test Fdb (CEI 50-6/9)
OPERATING CONDITIONS	CEI 50-3 EN 60068-2-1 Test Ab (IEC 60068-2-1) EN 60068-2-2 Test Bb (IEC 60068-2-2) IEC 60068-2-14 Test Nb IEC 60068-2-56 Test Cb IEC 60068-2-6 Test Fc IEC 60068-2-31 Test Ec IEC 60068-2-32 Test Ed - Method 1 IEC 60068-2-64 Test Fdb (CEI 50-6/9)
EMC	EN 55022 EN 55024 EN 61000-3-2 EN 61000-3-3 FCC15 *
SAFETY	EN 60950-1 (IEC 60950-1)

* Equipment for USA market only



Aethra S.p.A.

Via Matteo Ricci, 10
60126 Ancona (Italy)

Tel: +39.071.218981

Fax: +39.071.887077

Video: +39.071.2189701

Email: info.aethra@aethra.com www.aethra.com

Cod. 074201008GB